

## FieldQ Actuator QBR

### The Application

In a Pressure Swing Adsorption (PSA) application, the opening and closing of a valve controlling the passing of gas in and out of a pressurized chamber is critically important to the efficient and safe operation. The valve is inevitably driven by the actuator and therefore it in turn must perform flawlessly for hundreds of thousands of cycles, often in a short period of time. Actuators for valves in PSA service see high cycle counts and must provide tight bi-directional shutoff.

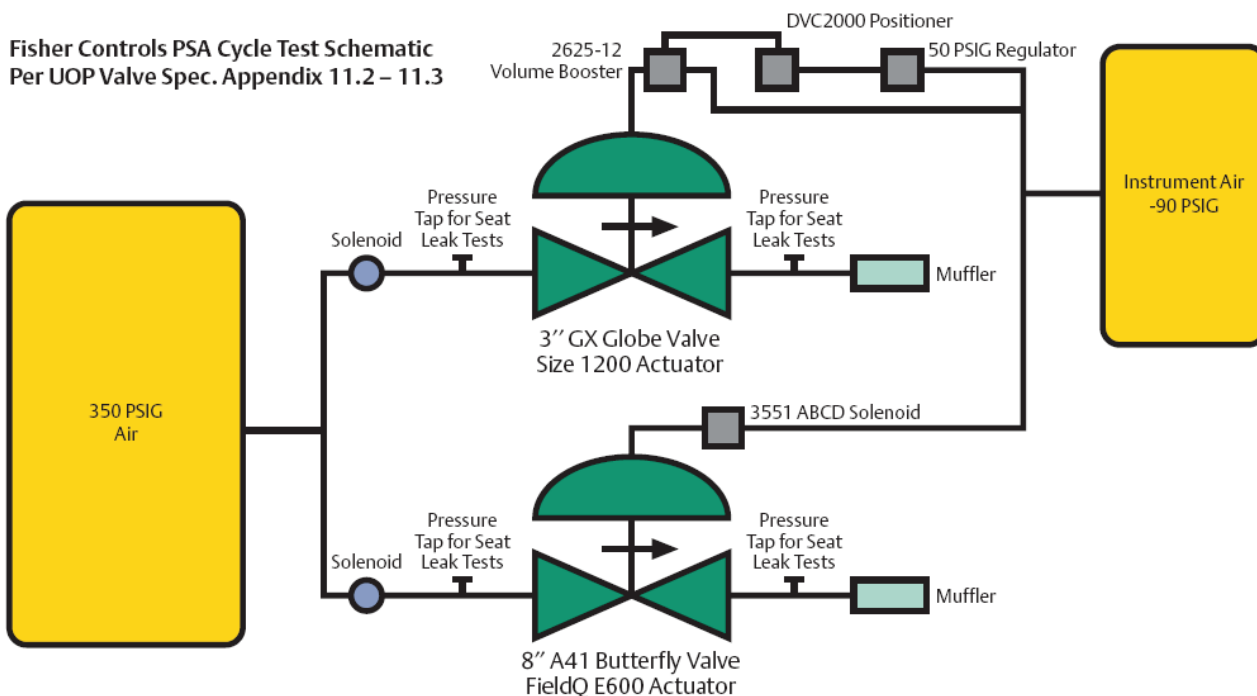

### The Test

Emerson's FieldQ actuator was therefore the obvious choice to prove the effectiveness of the valve and actuator package when UOP sponsored a performance test, carried out by Fisher test engineers. The test was designed to conform to the PSA Design Manual Valve Specification, Appendix II as provided by UOP in March of 2006. The test plan called for each assembly to be cycle tested against a pressure drop, with seat leakage data and maintenance and repair to be recorded at regular intervals. A FieldQ QS0600 actuator was direct mounted to an 8 inch A41 butterfly valve and coupled with an ASCO 8551 solenoid.

The test procedure commenced with leak testing performed every 5,000 cycles, and continued until several 500,000 cycles were accumulated. The valve and actuator were then inspected for wear.

## The Results

- Upon disassembly and careful inspection of the actuator's internal parts after the first 500,000 cycles, the actuator showed little to no wear. The springs appeared as new.
- Similarly, the rack and pinion assembly did not have any wear.
- After more than 1 Million cycles, only the piston o-rings were beginning to wear a flat spot along the outside diameter, but they still held a tight seal.
- In a similar test, an assembly consisting of a QS0200 on a 4 inch A41 also logged 1 million cycles without any performance degradation.



Spring Set

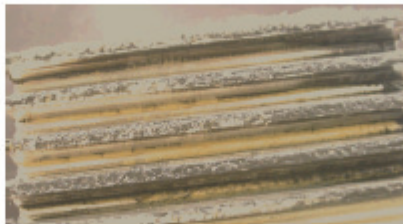

Rack and Pinion



Piston O-Ring